

8 7 6 5 4 3 2 1

REVISIONS				
ZONE	REV	DESCRIPTION	DATE	APPROVED
ALL	-	ORIGINAL ISSUE	04 FEB 10	P. KOTZEBUE
--	A	GENERAL UPDATE	01 SEP 10	P. KOTZEBUE

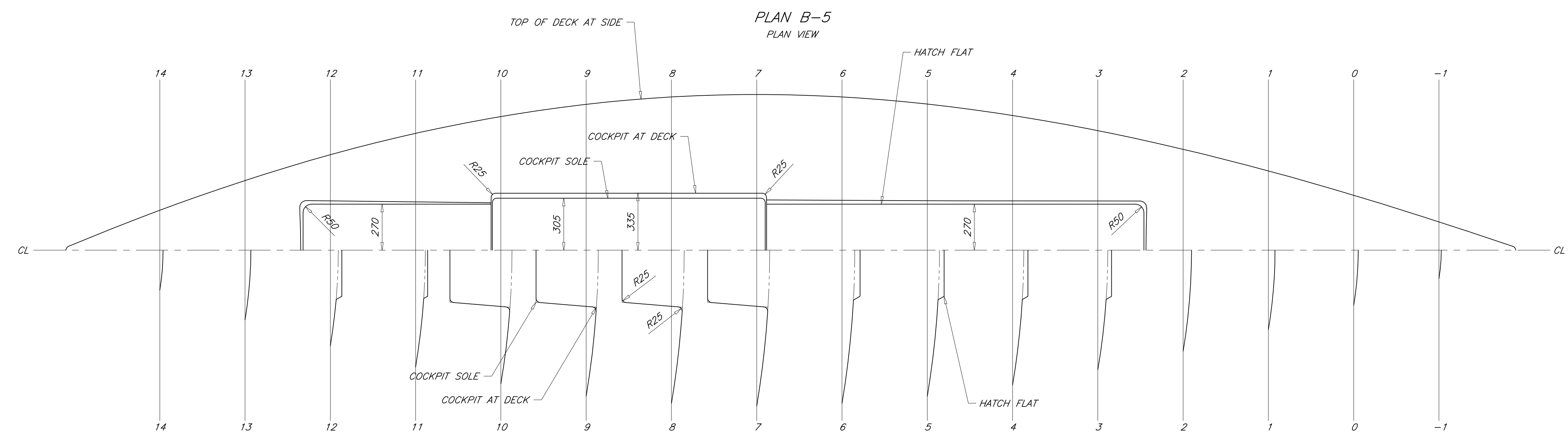
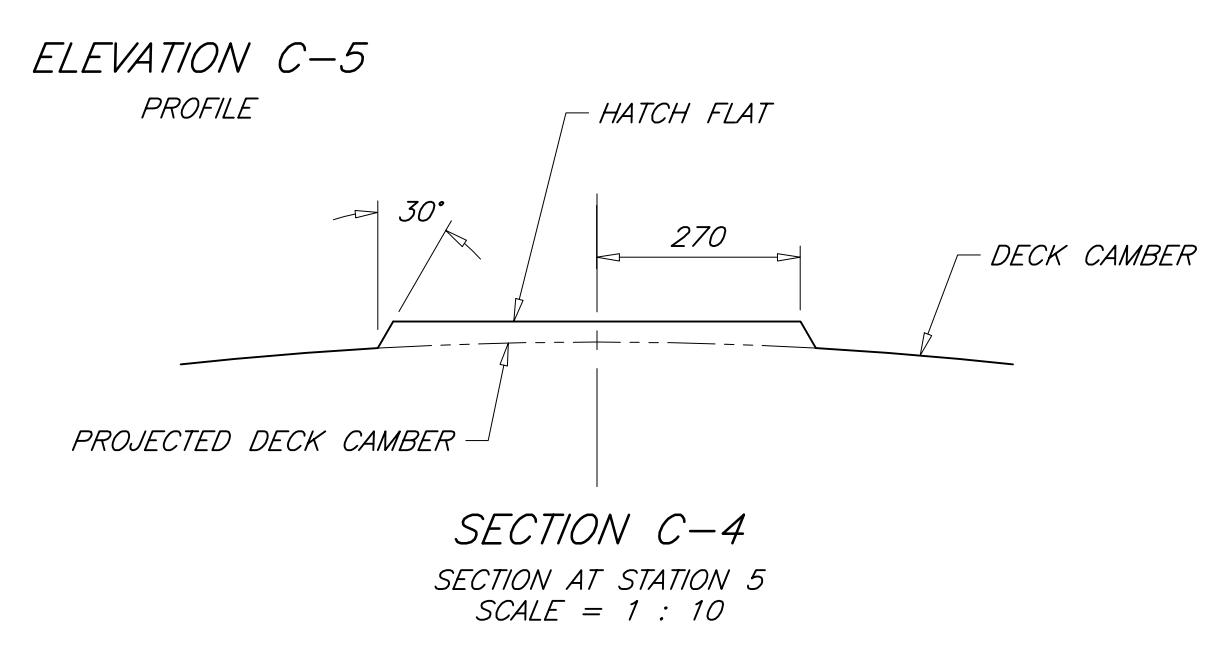
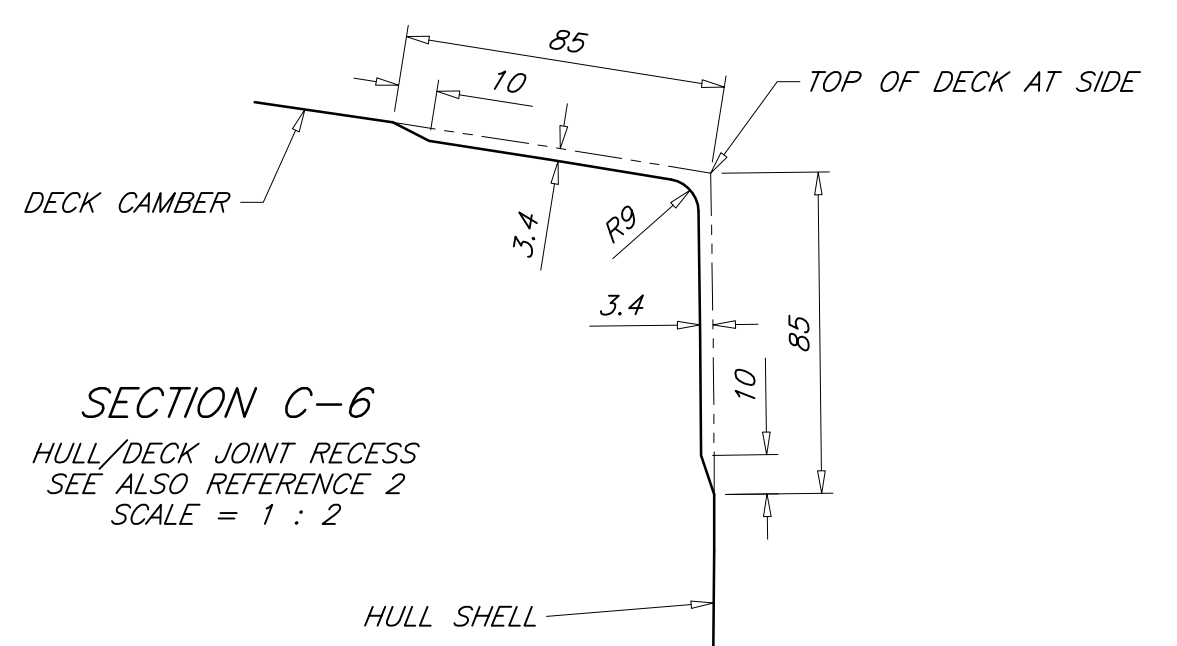
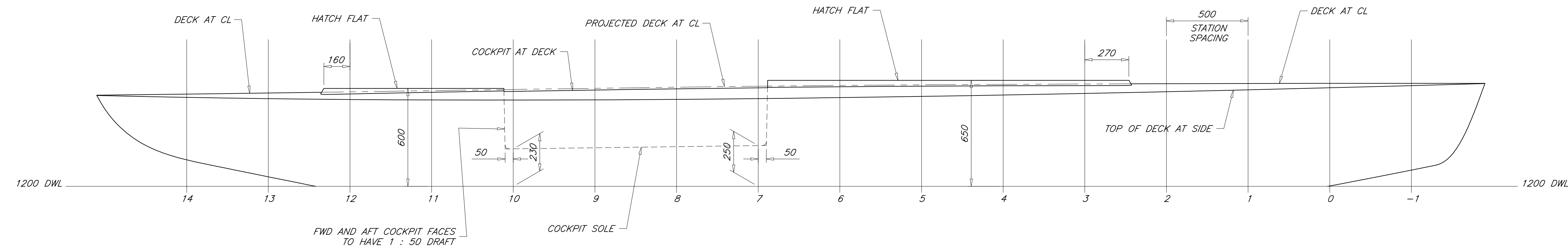

- GENERAL NOTES**
1. ALL LINES ARE TO OUTSIDE SURFACE OF DECK, CABIN, AND COCKPIT.
 2. ALL DIMENSIONS ARE IN MILLIMETERS.
 3. SEE REFERENCE 1 FOR DECK OFFSETS.

SECTIONS A-5 STATIONS

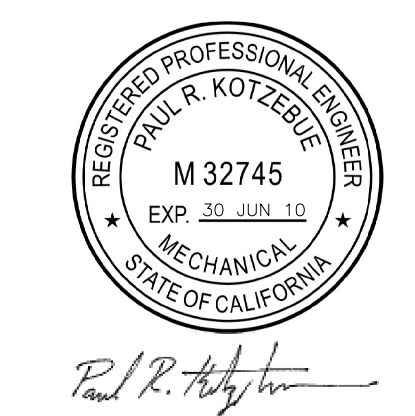

THIS DRAWING REMAINS THE PROPERTY OF PAUL R. KOTZEBUE, PE AND MAY NOT BE USED FOR ANY PURPOSE WITHOUT WRITTEN CONSENT.

2	CONSTRUCTION DETAILS	06-C3
1	TABLE OF OFFSETS	06-A4
NO	TITLE	DWG NO

REFERENCES	
STOCK PLANS	
8.50 METER SKERRY CRUISER	
DECK LINES	

PAUL R. KOTZEBUE, PE MECHANICAL ENGINEER Encinitas, California USA			
DRAFTER: PK	DATE: 04 FEB 10	SIZE: ARCH D	DWG NO. 06-A2
CHECKER: PK	DATE: 04 FEB 10	SCALE: 1 : 15	SWBS: --
			REV: A
			SHEET: 1 OF 1

8 7 6 5 4 3 2 1