

PARTS LIST

| NO. | QTY | DESCRIPTION | MANUFACTURER | MODEL NO |
|-----|-----|-----------------------------|---------------|----------------------------------|
| 1 | 2 | PRIMARY WINCHES | LEWMAR | 46ST ALLOY |
| 2 | 2 | MAINSHEET / HALYARD WINCHES | LEWMAR | 30ST ALLOY |
| 3 | 2 | ROPE CLUTCHES | LEWMAR | D1 TRIPLE 10-12 mm |
| 4 | 2 | MAINSHEET STAND UP BLOCKS | SCHAEFER | 704-62 |
| 5 | 1 | 1 1/4" GENOA TRACK | SCHAEFER | 40-76 (TO BE CUT IN HALF) |
| 6 | 2 | GENOA SHEET LEAD BLOCKS | SCHAEFER | 32-97 |
| 7 | 1 | DOUBLE DECK ORGANIZER | SCHAEFER | 504-80 |
| 8 | 2 | SPINNAKER SHEET PADEYE | SCHAEFER | 78-01 |
| 9 | 2 | SPINNAKER SHEET BLOCK | SCHAEFER | 704-05 |
| 10 | 1 | SPINNAKER TACK PADEYE | SCHAEFER | 78-01 |
| 11 | 1 | SPINNAKER TACK BLOCK | SCHAEFER | 704-05 |
| 12 | 1 | DECK ACCESS PLATE | BECKSON | DP40-W |
| 13 | 1 | STEMHEAD FITTING | CUSTOM | SEE REFERENCE 1 |
| 14 | 1 | BOW PULPIT | CUSTOM | 25 mm OD x 1.65 mm WALL SST TUBE |
| 15 | 1 | STERN PULPIT | CUSTOM | 25 mm OD x 1.65 mm WALL SST TUBE |
| 16 | | R E S E R V E D | | |
| 17 | 8 | LIFELINE STANCHIONS | SIGNET MARINE | 610 mm WITH MINI BRACE |
| 18 | 2 | TOE RAIL | CUSTOM | SEE DETAIL D-4 |
| 19 | 1 | MAST COLLAR | SPAR MFR | PER MANUFACTURER |
| 20 | 1 | BOOM VANG CAM CLEAT | SCHAEFER | 70-29 |
| 21 | 2 | DECK HATCHES | LEWMAR | OCEAN SERIES 60 |
| 22 | 5 | MAST PADEYES | SCHAEFER | 78-01 |
| 23 | 5 | MAST BLOCKS | SCHAEFER | 704-05 |
| 24 | 1 | MAINSHEET PADEYE | SCHAEFER | 78-25 |
| 25 | 1 | MAINSHEET LOWER BLOCK | SCHAEFER | 704-05 |
| 26 | 1 | TRIPLE DECK ORGANIZER | SCHAEFER | 504-81 |
| 27 | 2 | COCKPIT DRAINS | FORESPAR | CF 250S 1 1/4 |
| 28 | 1 | TILLER HEAD FITTING | LEWMAR | 30 mm |
| 29 | 1 | MAINSHEET UPPER BLOCK | SCHAEFER | 704-25 |
| 30 | 2 | MAINSHEET BOOM BLOCKS | SCHAEFER | 704-05 |
| 31 | 1 | BOOM VANG | FORESPAR | YACHT ROD YR-L |

| REVISIONS | | | | |
|-----------|-----|----------------|-----------|-------------|
| ZONE | REV | DESCRIPTION | DATE | APPROVED |
| ALL | - | ORIGINAL ISSUE | 05 AUG 09 | P. KOTZEBUE |

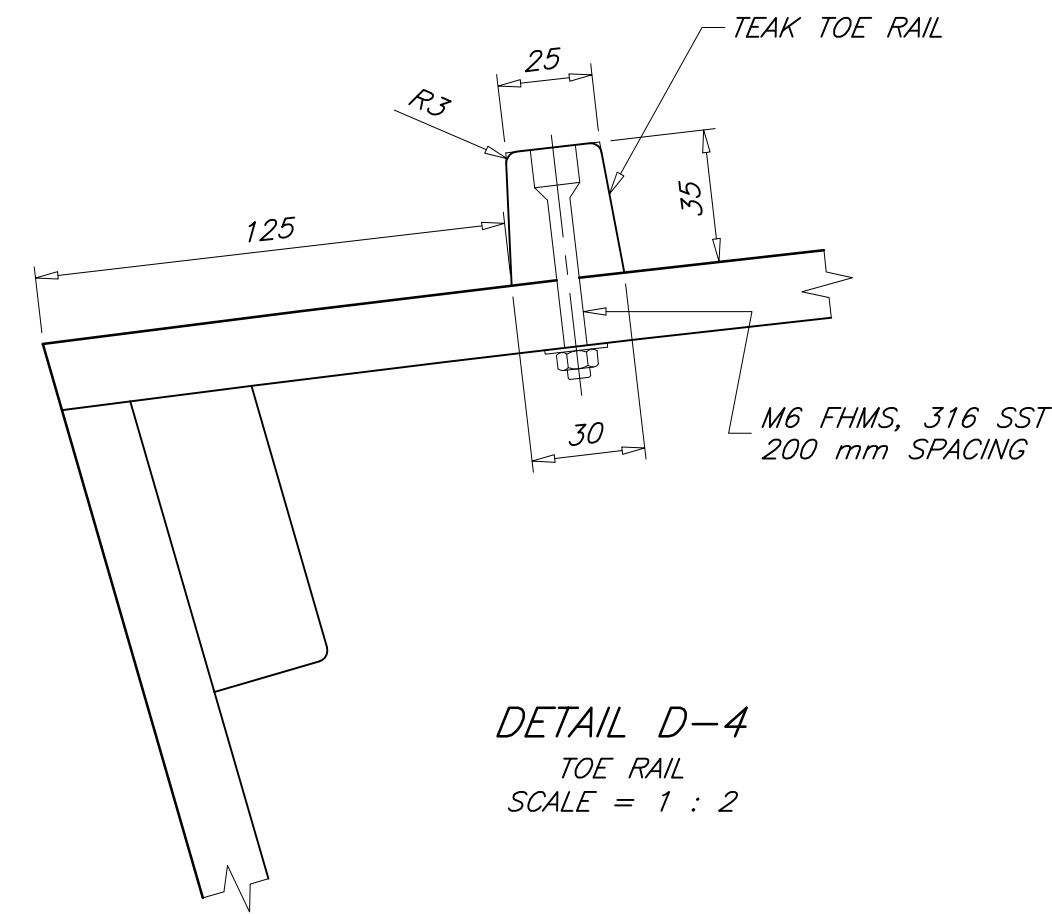

DETAIL D-4
TOE RAIL
SCALE = 1 : 2

GENERAL NOTES

- EQUIVALENT SUBSTITUTIONS FROM DIFFERENT MANUFACTURERS MAY BE MADE FOR ANY ITEM IN PARTS LIST.
- STAINLESS STEEL BACKING PLATES AND/OR FENDER WASHERS TO BE USED FOR ALL THRU-BOLTED DECK HARDWARE.

ITEMS NOT SHOWN:

- (29) MAINSHEET UPPER BLOCK
- (30) MAINSHEET BOOM BLOCKS
- (31) BOOM VANG

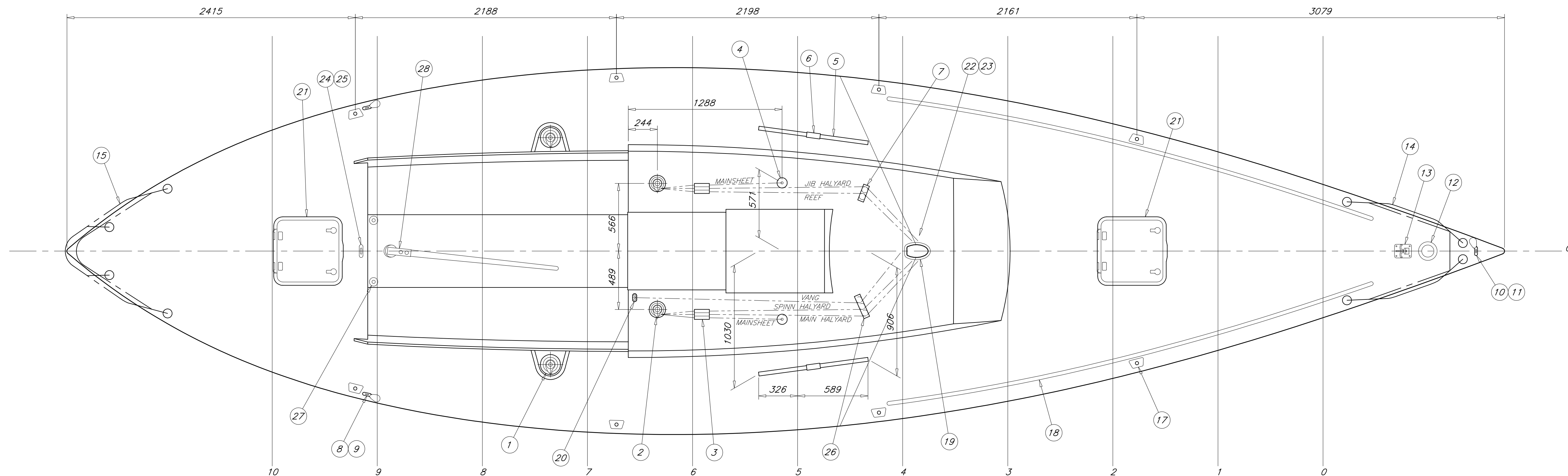

PLAN A-4
DECK PLAN

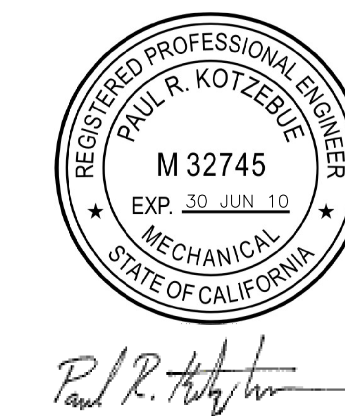

THIS DRAWING REMAINS THE PROPERTY OF PAUL R. KOTZEBUE, PE AND MAY NOT BE USED FOR ANY PURPOSE WITHOUT WRITTEN CONSENT.

| | | | |
|--------------------------|--------|-------------|-----------|
| 1 | | CHAINPLATES | 03-D2 |
| NO | | TITLE | DWG NO |
| REFERENCES | | | |
| STOCK PLANS | | | |
| 13.5 METER PLYWOOD SLOOP | | | |
| DECK PLAN | | | |
| DRAFTER: | PK | DATE: | 05 AUG 09 |
| CHECKER: | PK | DATE: | 05 AUG 09 |
| SIZE: | ARCH D | DWG NO: | 03-B3 |
| SCALE: | 1 : 20 | SWBS: | -- |
| REV: | - | SHEET: | 1 OF 1 |